



QUICK-FIT



THE WORLD'S FASTEST DUCTING

Nordfab Doesn't Leave You Hanging; They Support You In Ways Others Don't

Parts

Pipe Hanger



- 3"-24" made from galvanized steel 14 GA.
- Clearance hole 5/16".
- Bolts are supplied with hanger.
- Over 24 inches made from 3/16" flat bar steel.

Gripple Pipe Hanger



- Comes in length of 15 feet.
- Not available in SS.

Pipe Hanger HJ



- 3"-24" made from galvanized steel 14 GA.
- Clearance hole 7/16".
- Bolts are supplied with hanger.

Beam Clamp



- Speed up connection of pipe bracing to building steel members.

Pipe Bracing



- Galvanized.
- Supplied in standard length of 10 feet.
- Cut to desired length - flatten ends - drill one end with 3/8" bit - connect this end to pipe hanger and clamp or bolt other end to suspension point.
- NOT Flattened or Drilled.



If there are other ways NORDFAB can support you please contact your Local Sales Representative or call NORDFAB so we can connect you with your Local Sales Representative



QUICK-FIT



THE WORLD'S FASTEST DUCTING

Nordfab Doesn't Leave You Hanging; They Support You In Ways Others Don't

Pipe Stands

Note: This special type of pipe stand and hanger are used in certain situations, such as at trade shows and tight installations.

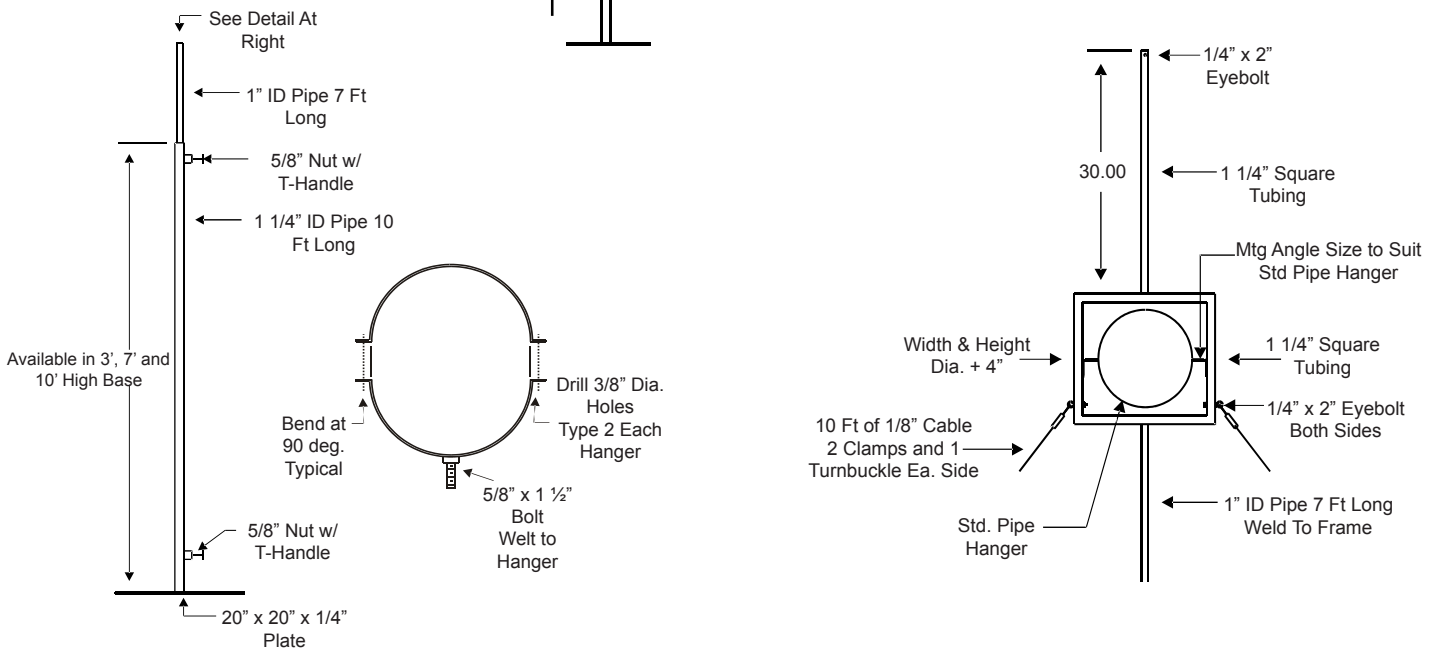
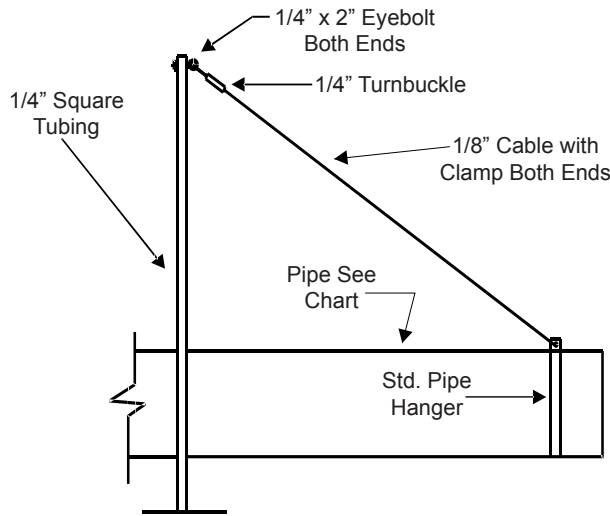

If there are other ways NORDFAB can support you please contact your Local Sales Representative or call NORDFAB so we can connect you with your Local Sales Representative



QUICK-FIT



THE WORLD'S FASTEST DUCTING

**Nordfab Doesn't Leave You Hanging;
They Support You In Ways Others Don't**

Mountings

Ceiling

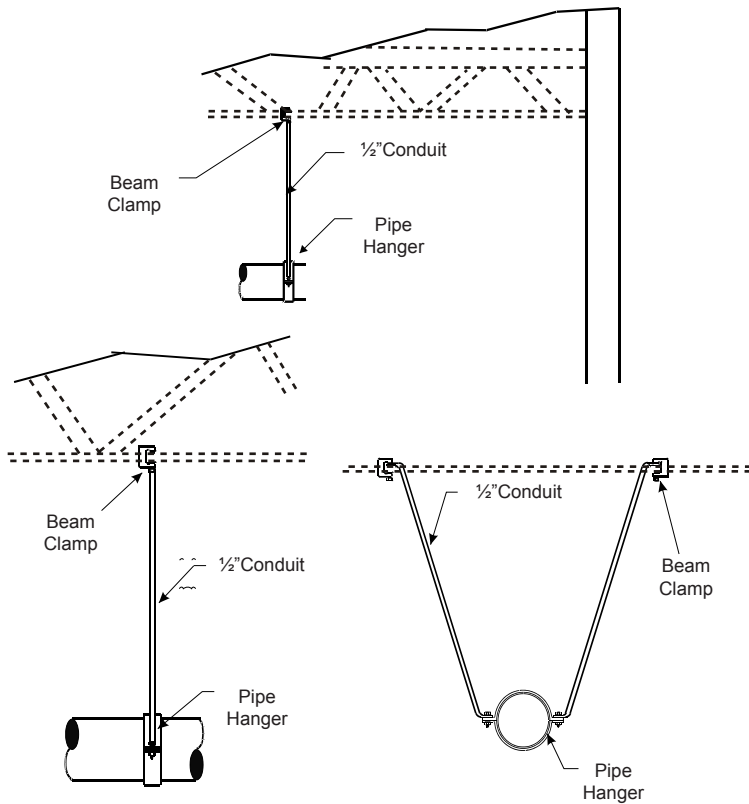

Wall

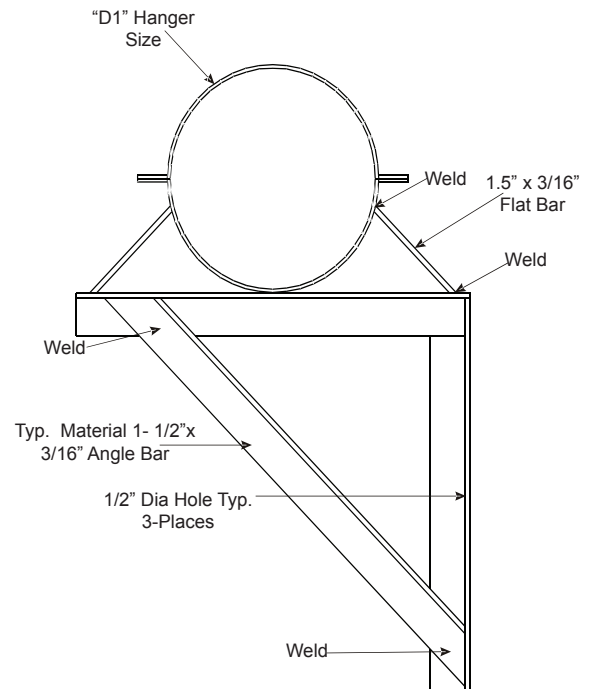

If there are other ways NORDFAB can support you please contact your Local Sales Representative or call NORDFAB so we can connect you with your Local Sales Representative